

Narrow Wall Bracing Method

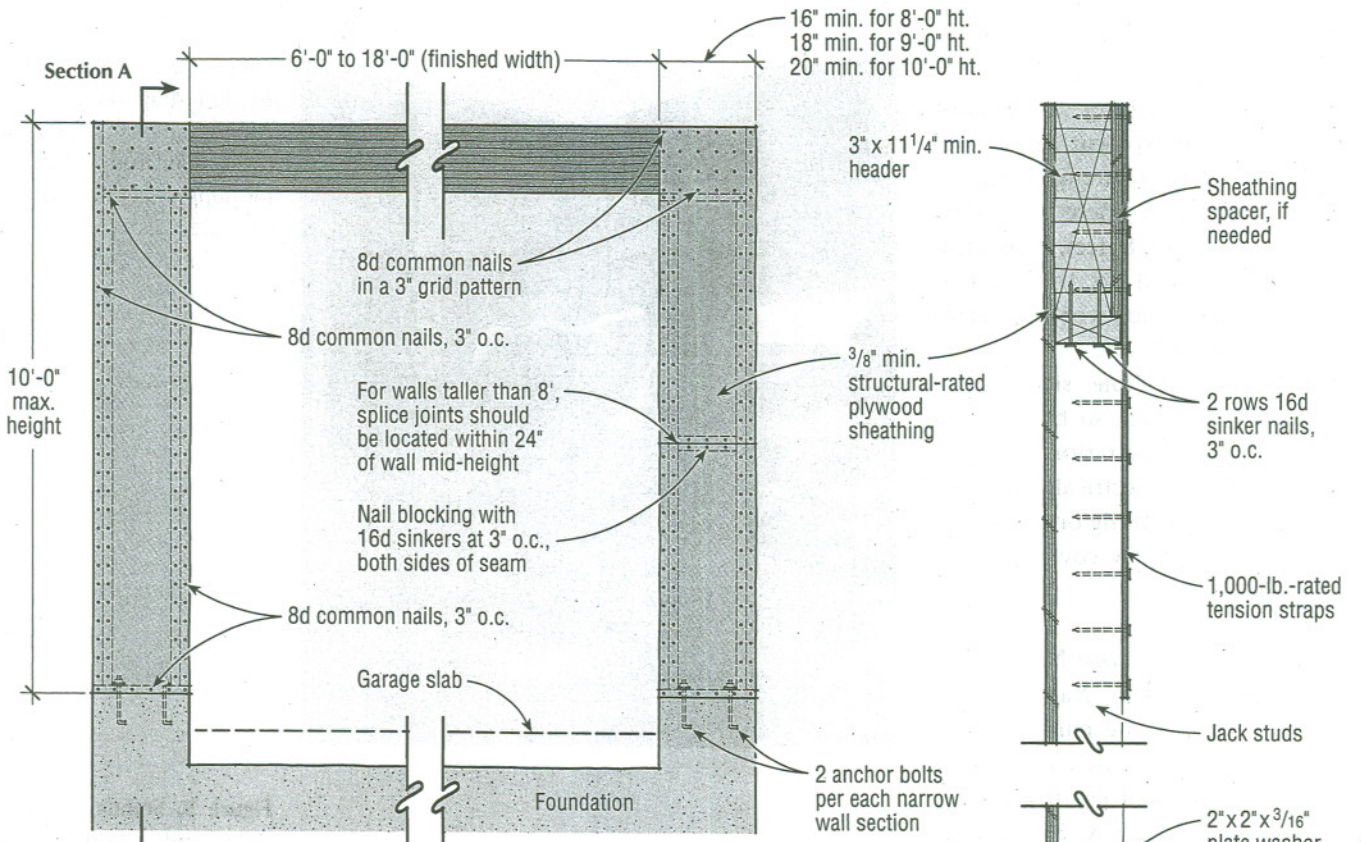

Outside Elevation

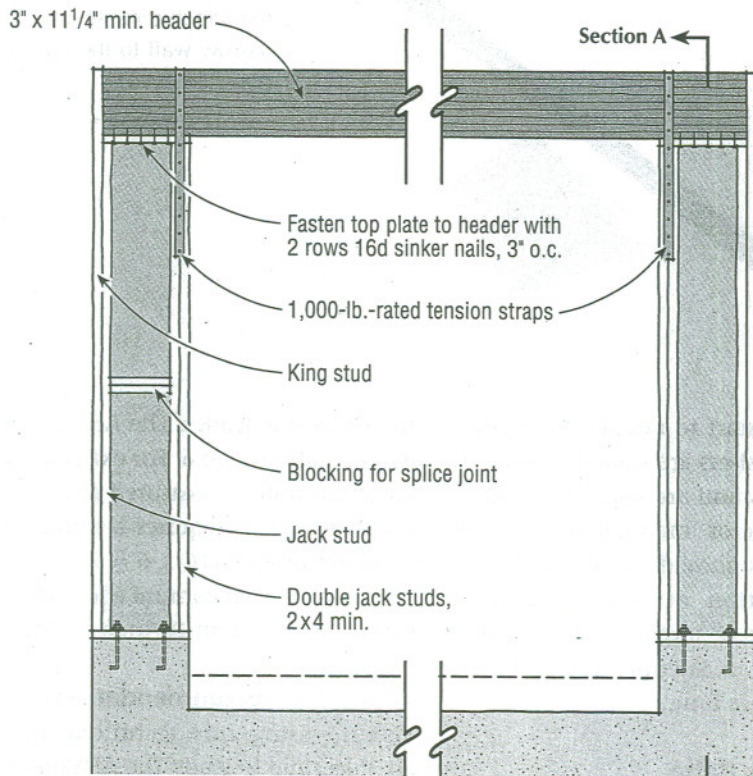

Inside Elevation

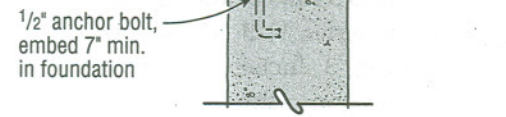

Section A

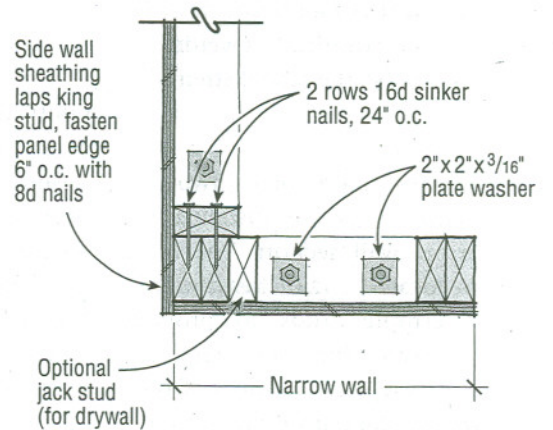

Corner Detail - Plan View